

les freins

I Fonction :

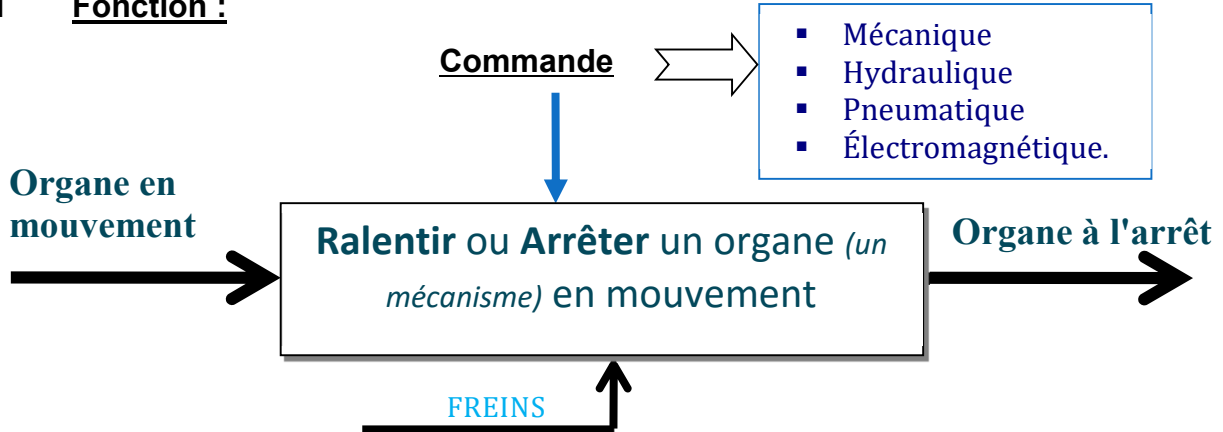

II Symbole Normalisé

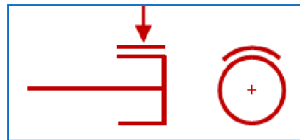

III Principes de freinage

Frein à disque	Frein à sangle	Frein à sabot	Frein à mâchoire

IV Différent types :

1) Frein à disque à étrier :

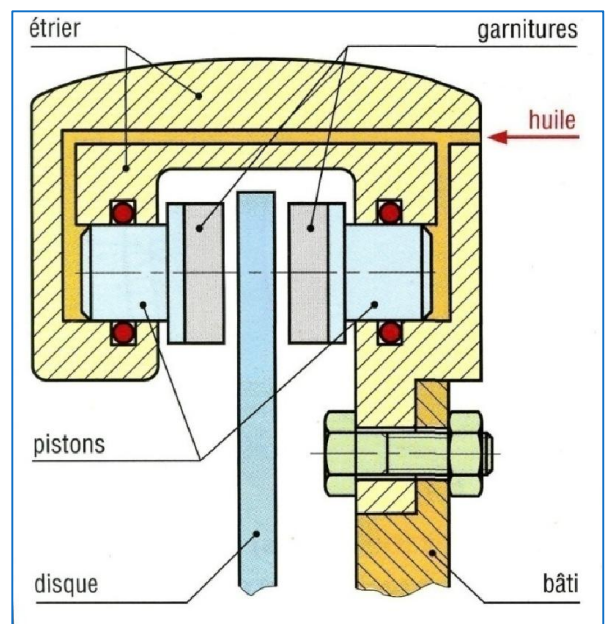
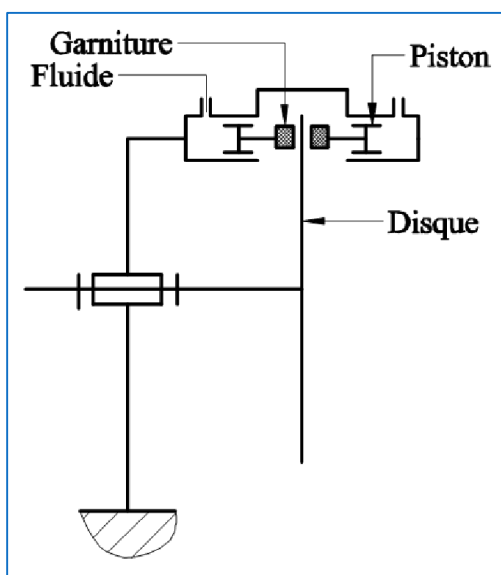

Transmettre l'énergie mécanique

2) Frein à tambour

1) Principe

Mâchoires

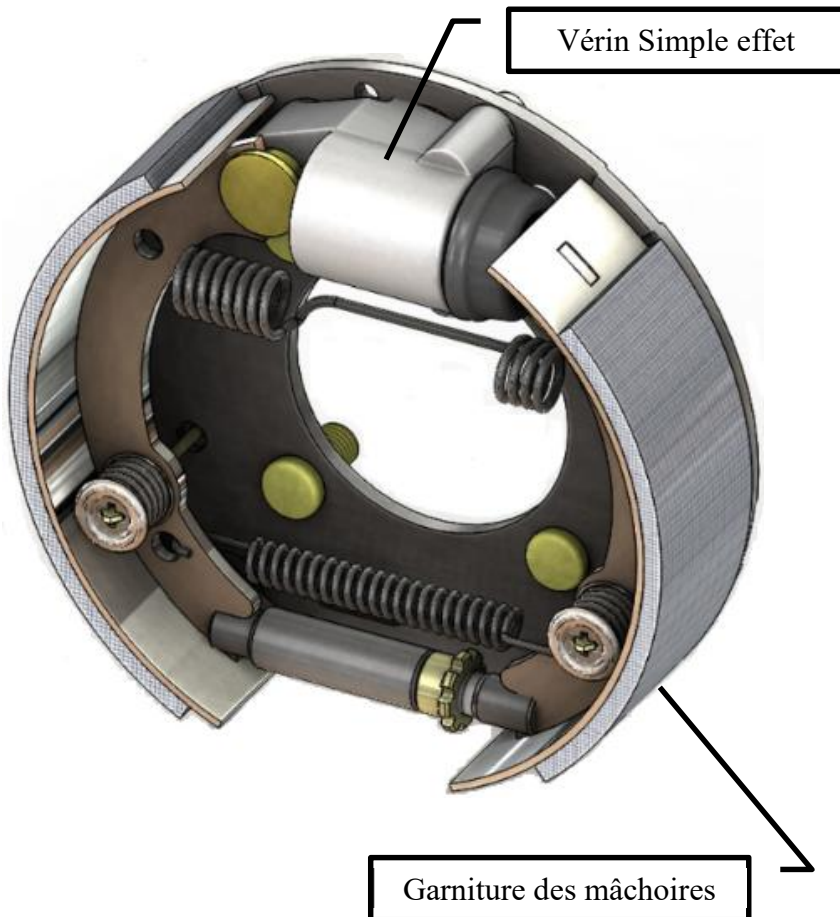

2) Représentation :

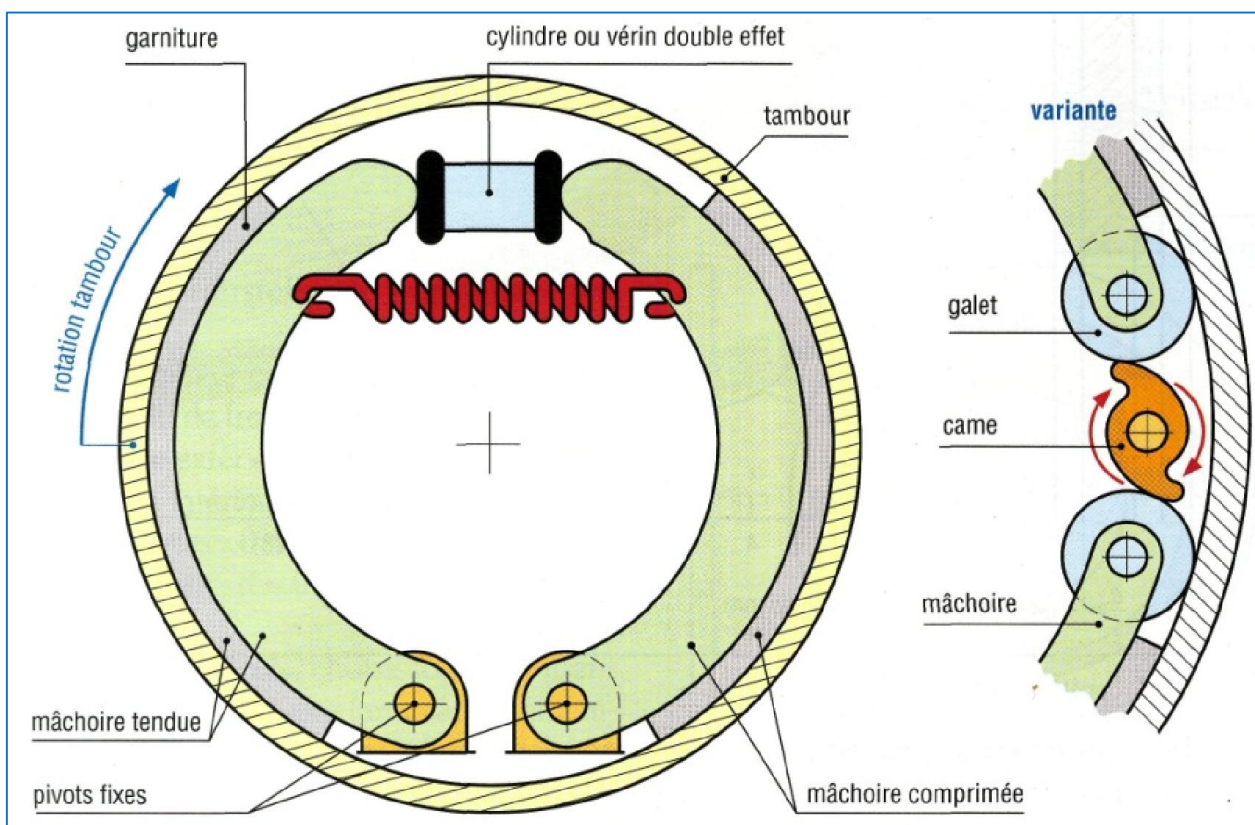

3) Frein à friction plane mono-disques.

La commande de ce frein est:

.....
.....

Le rôle des ressorts 5 est:

.....
.....

Le couple de freinage est:

.....
.....

